

Wheel Loaders

# L 526 - L 546

**Generation**

6

**Tipping load**

8,000 – 10,500 kg

**Engine**

Stage V



# LIEBHERR

## Performance

Power for Increased  
Productivity

## Economy

Minimum Costs at  
High Handling Capacity

### L 526

**Tipping load, articulated**

8,000 kg

**Bucket capacity**

2.1 m<sup>3</sup>

**Operating weight**

11,770 kg

**Engine output (ISO 14396)**

100 kW/136 HP

### L 538

**Tipping load, articulated**

9,500 kg

**Bucket capacity**

2.6 m<sup>3</sup>

**Operating weight**

13,500 kg

**Engine output (ISO 14396)**

120 kW/163 HP

### L 546

**Tipping load, articulated**

10,500 kg

**Bucket capacity**

2.8 m<sup>3</sup>

**Operating weight**

14,200 kg

**Engine output (ISO 14396)**

138 kW/188 HP

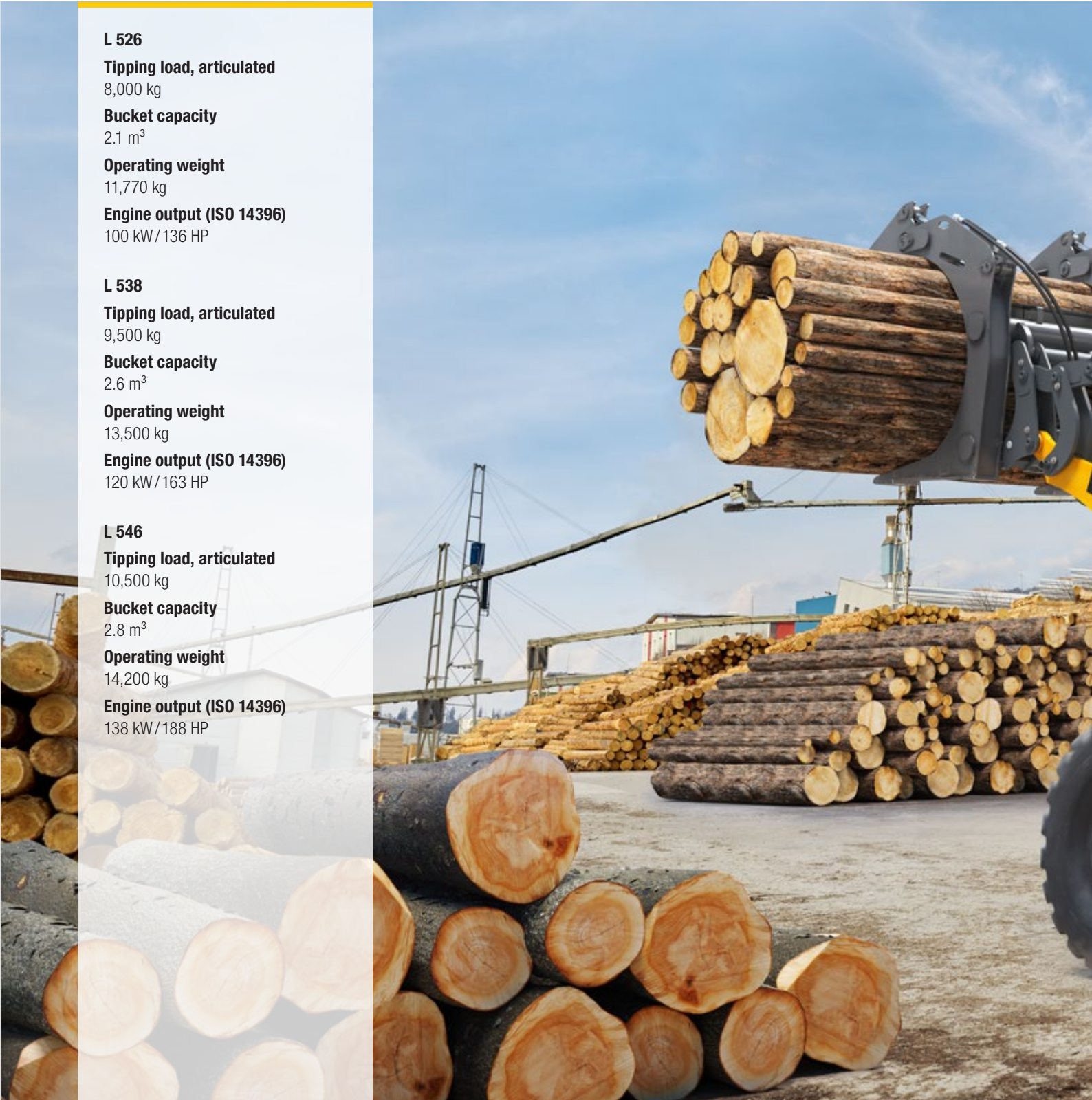

## Reliability

Robustness and Quality  
for Durable Machines

## Comfort

Maximum Operator Comfort  
for More Productivity

## Maintainability

Time and Cost Savings  
Through Simple Maintenance



# Performance



## Power for Increased Productivity

The innovative Liebherr driveline considerably increases working efficiency. Quick working cycles, high tipping loads and high machine availability lead to increased handling capacity.

# Powerful and Efficient Machine Concept

## Highest Level of Performance

The high-performance Liebherr wheel loaders L 526 – L 546 are genuine all-rounders that impress in every field of application due to their great productivity and efficiency. High tipping loads at low operating weight permit a high handling capacity. Strong construction and rugged steel components result in reliable and powerful performance. All of the components are perfectly adapted to each other, making the all-round loaders the perfect solution for all applications, especially for industrial use. The wide variety of options for specific requirements also increases the range of possible applications.

## Continuously Variable Transmission

The Liebherr driveline allows continuous regulation of acceleration in all speed ranges, without noticeable gear shifting or interruption in tractive force. Powerful working and high driving comfort increases your productivity.

## High Handling Capacity

Unnecessary counterweight can be avoided through the unique component mounting position at the rear of the machine. Ideal weight distribution results in higher tipping loads at significantly lower operating weight, compared with conventional wheel loaders. The handling capacity per operating hour increases and fuel consumption is further reduced thanks to the low operating weight.

# Flexibility and Versatility

## Lift Arm Variants Optimised for the Application

The standard Z-bar linkage provides a large torque in the lower region of the lift arm. The ideal prerequisite for conventional wheel loader applications – simple, quick filling of the bucket leads to high handling capacity.

An alternative is available in the form of the parallel linkage for the entire range of all-round wheel loaders. The parallel linkage boasts a parallel guide arrangement and especially high torque in the upper lifting range. The best solution for industrial use as it allows large attachments to be fitted for transporting heavy loads.

## Optimal Bucket Filling

The robust bucket design from Liebherr allows the bucket to be filled quickly and efficiently. Fully filled attachments increase productivity. The bucket's good penetration and simple filling mechanism result in lower fuel consumption.

## Wide Range of Applications

The wide range of attachments means the right tool is always to hand. As a result, a multitude of uses can easily be covered. This increases utilisation of the machine and raises productivity. Liebherr wheel loaders can manoeuvre quickly and efficiently thanks to their compact design – the best choice for high handling capacity.

### Liebherr Driveline

#### L 526 – L 546

- Optimum weight distribution due to its unique component mounting position
- Higher tipping loads at low operating weight
- Ideal visibility due to its compact design

### Conventional

#### Travel Gear

- Centre of gravity in the middle of the machine
- Additional ballast is needed to increase the tipping load and improve stability
- This leads to high operating weight and bad visibility

### An All-Purpose

#### Loader

The option to choose between parallel linkage and Z-bar linkage means the right machine is always available for the use specifically required by the customer.

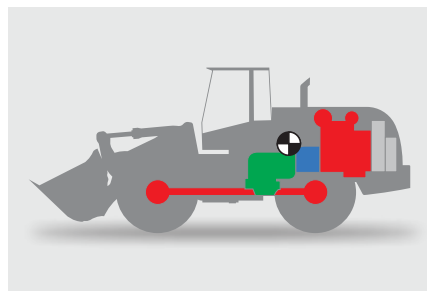
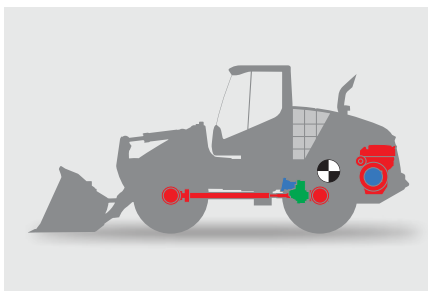

# Economy



## Minimum Costs at High Handling Capacity

Liebherr wheel loaders make a reliable contribution to commercial success. The fuel-efficient drive concept reduces operating costs and environmental impact at maximum handling capacity.

# Low Operating Costs

## Lower Fuel Consumption

The Liebherr driveline with Liebherr-Power-Efficiency (LPE) achieves a reduction in fuel consumption of up to 25%. At highest efficiency this reduces operating costs and increases profitability.

## Hardly Any Brake Wear

The Liebherr driveline brakes automatically. The service brake only acts as a support and is therefore subject to hardly any wear.

## Minimal Tyre Wear

Its continuous traction control, combined with automatic self-locking differential, prevents wheelspin. Productivity is increased and tyre wear reduced by up to 25%.

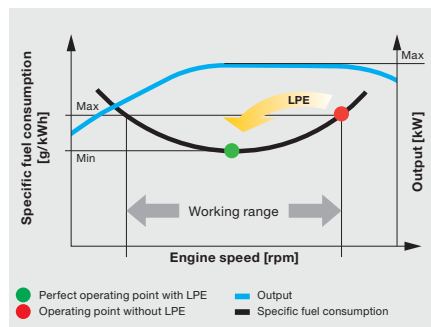

## Low Fuel Consumption Thanks to Intelligent Machine Control

- Liebherr-Power-Efficiency (LPE) optimises the interaction between diesel engine, gearbox and working hydraulics for maximum efficiency
- LPE – maximum performance from every drop of fuel

# Save Costs and Protect the Environment

## Innovative Exhaust Gas Treatment

The exhaust gas treatment system is fitted with a diesel oxidation catalyst (DOC), a diesel particle filter (DPF) and selective catalytic reduction (SCR) so as to reduce exhaust emissions. This time-tested solution is state-of-the-art in this machine class and effectively reduces exhaust emissions.

## Economical Use of Resources

The lower fuel consumption and efficient exhaust gas treatment cut emissions. This actively saves resources. While actively protecting the environment, Liebherr wheel loaders reduce operating costs.



## Reduced Brake Wear

Hardly any brake wear due to hydraulic braking action of the driveline

## Reduced Tyre Wear

Continuous traction control prevents the wheels from spinning

# LiDAT

## Efficient Management

LiDAT, Liebherr's own data transmission and positioning system, facilitates efficient management, monitoring and control of the entire fleet park in terms of machinery data recording, data analysis, fleet park management and service. All of the important machinery data can be viewed at any time in a web browser. LiDAT offers you comprehensive work deployment documentation, greater availability thanks to shorter downtimes, faster support from the manufacturer, quicker detection of strain / overload and subsequently a longer service life of the machine as well as greater planning efficiency in your company. This service includes 1 year of use free of charge as standard for the L 526 – L 546 wheel loaders.



## Always Be Informed with LiDAT

- Evaluation of machine usage and fuel consumption for economic machine management
- LiDAT comes as standard incl. 1 year free-of-charge use

# Reliability



## Robustness and Quality for Durable Machines

Liebherr wheel loaders provide maximum performance even under the toughest of operating conditions. Specially-developed components, sophisticated technology and high quality offer a high level of reliability and availability.



## OEM Quality Components

### Durable and Powerful

Liebherr has many decades of experience in the development, construction and production of components. Ideally adapted to each other, they guarantee a high degree of performance and reliability. Liebherr also develops and produces all steel components. These rugged components ensure the long life of the wheel loaders.

Strenuous endurance tests prove to the strength and quality of the components in use. Even under the toughest of usage conditions, Liebherr wheel loaders satisfy Liebherr's stringent quality standards. This ensures reliable use throughout the entire life time of the machine. Consistently powerful machines increase productivity.



### Powerful Liebherr's Own Components

- Ideal interaction of components to each other for maximum performance
- Maximum endurance even under the toughest operating conditions
- Rugged, durable machines for reliable operations

## High Safe and Versatile Usage

### Liebherr Drive Concept

The components of the tried and tested hydrostatic Liebherr driveline are extremely robust and powerful. This ensures that the machine has a long life time and will work reliably even under the toughest of operating conditions.

### Continuous Use

The diesel particle filter can be burned free by active regeneration during operation in the usual manner, thus allowing uninterrupted operation. The long intervals between regeneration increase productivity, save fuel and reduce operating costs.

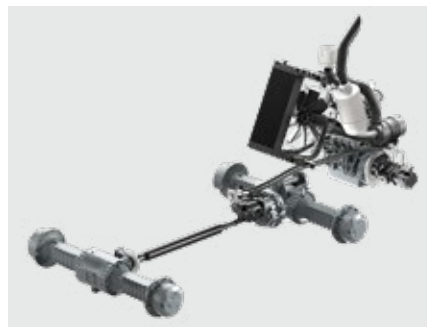

### High Machine Availability

- High, safe and versatile usage thanks to robust and powerful components
- Tried and tested exhaust gas treatment system
- Continuous use thanks to active regeneration during operation

## Reliable Cooling System

### Optimal Cooling Performance

The cooling system is fitted directly behind the operator's cab and is thus able to take in air which is free of dust. In especially dusty applications, optional equipment such as reversible fan drive, fluff trap for the radiator and large-mesh radiator protect the cooling system from contaminants getting in. This guarantees continuous cooling output while simultaneously reducing cleaning expenses. Minimal cleaning expenses mean more efficient, more cost-effective working.

### Controlled Cooling

The cooling fan is driven independently from the diesel engine and produces exactly the cooling air output which is actually required. Heat sensors ensure reliable control.



### Intelligent Cooling System

- Cooling position on the cleanest position of the wheel loader
- High machine availability thanks to lower radiator contamination
- Controlled cooling through thermostatic control for reliable operations

# Comfort



## Maximum Operator Comfort for More Productivity

The cab design is optimally adapted to the operator's day-to-day requirements. The roomy and ergonomic operator's cab offers perfect conditions for comfortable and productive work.

## Clearly Arranged Cab

### Productive and Safe Working

The modern, ergonomic cab design allows the operator to work with high concentration without fatigue – this increases safety and productivity. The displays, controls and operator's seat are carefully coordinated to form an ergonomic unit. The operating and control instruments are well laid out and user-friendly. All operation-relevant data can be viewed quickly and efficiently. The high operating comfort allows the operator to work particularly efficiently and safely.

### Perfect Visibility

The generous glass surfaces of the cab offer exceptional all-round visibility of the attachment and working area. The design of the engine hood which has been optimised for viewing provides ideal viewing towards the rear as well as monitoring behind the machine from the Liebherr display. This ensures maximum safety for people, the machine and the load, while increasing productivity at the same time.

### Well-Being Guaranteed

Optimum storage areas and stowage spaces and optional cool-box increase operator well-being. The optional air conditioning system with improved cooling output ensures a pleasant working atmosphere. This gives the operator maximum comfort and high productivity.

#### Exceptional All-Round Visibility

- Unobstructed visibility in all directions through optimal cab and engine hood design
- Generous glass surfaces
- More safety and productivity thanks to exceptional visibility



## Simple and Intuitive Operation

### Joystick Steering (optional)

The optional joystick steering integrated into the operator's seat is a new, innovative and improved steering system. All the machine's working and driving functions can be controlled precisely and with a high degree of sensitivity. The intuitive operation is similar to that of a steering wheel, and the joystick's orientation corresponds to the desired wheel loader articulation angle. In addition, the forces acting on the steering are transmitted to the joystick. This makes precise and safe operation possible at any speed.

The operator's cab is also optionally available without steering wheel and column with joystick steering only. Elimination the need for the operator to move their hands between the steering unit and the control unit increases safety and comfort.

### Touchscreen Display

The height-adjustable 9" touchscreen display, which comes as standard, allows all operating-relevant machine data to be viewed and configured quickly. Visual and acoustic warning devices ensure high operational reliability.

### LIKUFIX

LIKUFIX is a hydraulic quick hitch with an integral automated hydraulic coupling system, which is available as an option. A wide range of hydraulic and mechanical attachments can be changed fully automatically, safely and without any oil leaks direct from the cab in a matter of seconds by pressing a button. LIKUFIX contributes to higher utilisation of the wheel loader, thus increasing operational efficiency.

#### Joystick Steering (optional)

- Ergonomic and comfortable operation
- Speed-dependent force feedback for precise and safe steering behaviour
- Simple handling through intuitive operation



#### LIKUFIX

- Hydraulic attachments can be changed in seconds, direct from the cab – fully automatically, safely and without any oil leaks
- Comfort and time saving for increased productivity

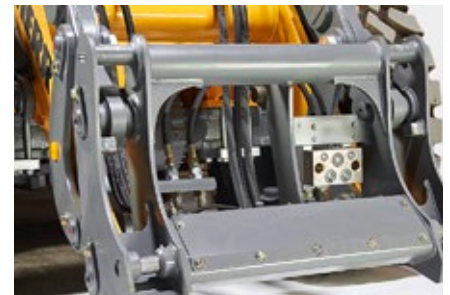

# Maintainability



## Time and Cost Savings Through Simple Maintenance

The most important points for daily maintenance of Liebherr wheel loaders can be reached safely and conveniently from the ground. Quick and safe checks save time and money.

# Exceptional Service Accessibility

## Efficient and Simple Maintenance

Thanks to the unique mounting position of the components, Liebherr wheel loaders offer exceptional accessibility for maintenance. The positioning of the cooling package directly behind the operator's cab lowers contamination of the cooling system, reducing maintenance and cleaning requirements and saving time and money.

## Safe and Free Service Access

All points requiring day-to-day maintenance can be reached comfortably, safely and cleanly. Cleaning of the cooling system is carried out while standing on the machine, anti-slip steps and sturdy handrails provide a high degree of safety.

## Short Service Times for More Productivity

The entire engine compartment is accessible via just one access panel. Service points are easy to see and reach. Maintenance work can be carried out comfortably and safely from the ground. This ensures time-saving maintenance and increases productivity.

# Strong Service Partner

## Safe Partnership with Strong Service

When buying a Liebherr wheel loader the customer not only looks to a long-lived high-end product but also a reliable longterm partnership. A service network combined with a highly-modern central warehouse is available for optimum service and quick replacement part provision. This guarantees short routes and rapid support in the event of service. Round-the-clock if required.

## Competent Liebherr Service Offers Maximum Reliability

Comprehensive know-how ensures a first-class execution of all service and maintenance work. This contributes decisively to the availability and profitability of your machine. Employees at Liebherr service partners are trained on an ongoing basis. They have extensive knowledge of quick and safe service performance. They can turn to the expertise of manufacturing plants at any time.

### Low Maintenance

- Less contamination of the radiator thanks to its clever position behind the operator's cab
- Quick and safe control saves time and money

### Optimum Service Accessibility

- The entire engine compartment is accessible via just one enclosure
- All points for daily maintenance can be reached from the ground
- Short downtimes means more efficiency

### Perfect Service for Optimum Machine Availability

- Quick and effective support thanks to an extensive service network
- Replacement parts service with 24-hour delivery
- Quick and reliable service carried out by qualified service specialists



# Wheel Loaders L 526 - L 546

## Overview

### Sturdy Attachment

- + Quick working cycles
  - + Robust, durable lift arm
  - + Flexible in use
  - + Efficient and cost-optimised use by specially adapted lift arm variants
- 
- ✓ High-quality hydraulic components
  - ✓ Strong steel construction
  - ✓ Wide range of attachments
  - ✓ Parallel linkage and Z-bar linkage optional

### Powerful and Efficient Liebherr Driveline

- + Fuel benefit of up to 25 %
  - + High performance
  - + High safe and versatile usage
  - + Maximum productivity by high tipping load
  - + Tyre wear reduced by up to 25 %
  - + Practically no brake wear
  - + Maximum stability and safety on all terrains
- 
- ✓ Most efficient hydrostatic driveline
  - ✓ Drive components optimally suited to each other by LPE
  - ✓ Rugged and durable driveline
  - ✓ Ideal weight distribution by intelligent arrangement of drive components
  - ✓ Continuous tractive force prevents wheelspin
  - ✓ Self-locking hydraulic brake system





### **Comfortable Operator's Cab**

- + Increased performance and productivity
  - + Focused operator work is supported
  - + Easy and safe operation
  - + Excellent all-round visibility
- 
- ✓ New, modern and ergonomic cab design
  - ✓ Control of working and travel functions with Liebherr control lever mounted into the operator's seat
  - ✓ Generous glass surfaces

### **Intelligent Cooling System**

- + Constant and reliable cooling
  - + Increased service life of components
  - + High machine availability through minimal cleaning expenses
- 
- ✓ Controlled cooling
  - ✓ Heat sensors ensure reliable control
  - ✓ The radiator is installed directly behind the operator's cab – the cleanest position of the wheel loader

### **Optimum Service Accessibility**

- + Time savings in daily maintenance
  - + Short service times for more productivity
  - + High availability and fast support from the manufacturer
- 
- ✓ Rapid control of all maintenance points from the ground
  - ✓ Safe, simple and quick access to all points important for operations
  - ✓ LiDAT – fleet park management for machinery data recording and diagnostics

# Technical Data



## Engine

	L 526	L 538	L 546
<b>Diesel engine</b>	4045HB551	4045CB551	6068HB551
Design	Water-cooled turbocharged in-series engine with cooled exhaust gas recirculation		
Cylinder inline	4	4	6
Fuel injection process	Electronic Common Rail high-pressure injection		
Max. gross output to ISO 3046 and SAE J1995	kW/HP 103/140 at RPM 2,000	125/170 2,000	138/188 2,200
Max. net output to ISO 9249 and SAE J1349	kW/HP 101/137 at RPM 2,400	121/165 2,400	135/184 2,400
Rated output to ISO 14396	kW/HP 100/136 at RPM 2,400	120/163 2,400	138/188 2,400
Max. gross torque to ISO 3046 and SAE J1995	Nm 555 at RPM 1,500	697 1,400	741 1,600
Displacement	litres 4.5	4.5	6.8
Bore/Stroke	mm 106/127	106/127	106/127
<b>Stage V</b>			
Harmful emissions values	According to regulation (EU) 2016/1628		
Emission control	SCR technology and closed diesel particle filter system		
Fuel tank (plastic design)	litres 205	205	205
Fuel tank (steel version, optional)	litres 205	205	205
DEF tank	litres 20	20	20
<b>Air cleaner system</b>	Dry type filter with main and safety element, pre-cleaner, service indicator on the Liebherr display		
<b>Electrical system</b>			
Operating voltage	V 24	24	24
Battery	Ah 2 x 135	2 x 135	2 x 135
Alternator	V/A 24/100	24/100	24/100
Starter	V/kW 24/7.8	24/7.8	24/7.8



## Driveline

<b>Continuous hydrostatic driveline</b>	
Design	Swash plate type variable flow pump and two variable axial piston motors in closed loop circuit and axle transfer case. Direction of travel is reversed by changing the flow-direction of the variable-displacement pump
Filtration	Suction return line filter for closed circuit
Control	By travel and inching pedal. The inching pedal makes it possible to control the tractive and thrust forces steplessly at full engine speed. The Liebherr control lever is used to control forward and reverse travel
<b>Travel speed range</b>	Speed range 1 _____ 0 – 8 km/h Speed range A1 – 2 _____ 0 – 16 km/h Speed range A1 – 3 _____ 0 – 40 km/h forward and reverse Speeds quoted apply with the tyres indicated as standard on loader model.



## Brakes

<b>Wear-free service brake</b>	Self-locking of the hydrostatic driveline (acting on all four wheels) and additional pump-accumulator brake system with wet multi-disc brakes located in the differential housing (two separate brake circuits)
<b>Parking brake</b>	Electro-hydraulically actuated spring-loaded disc brake system on the front axle

The braking system meets the requirements of the ISO 3450.

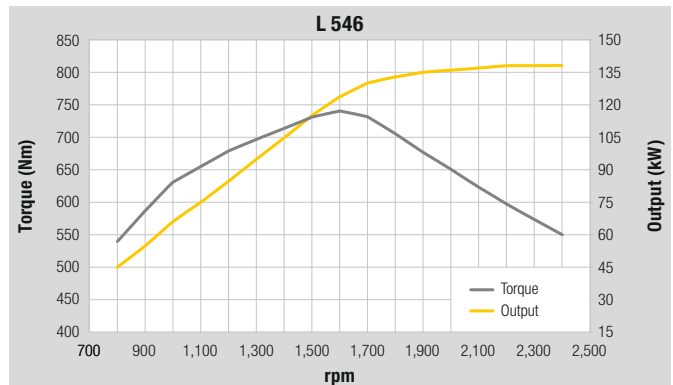
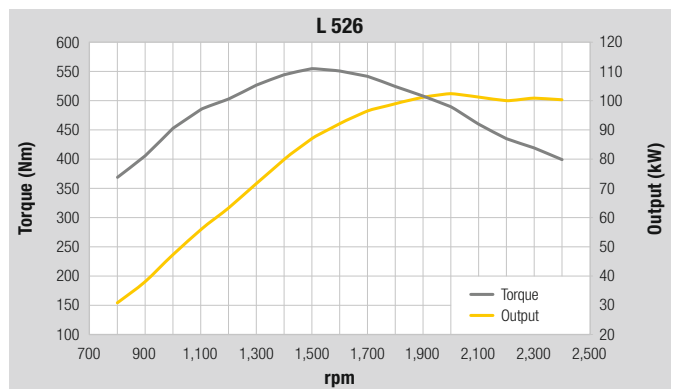
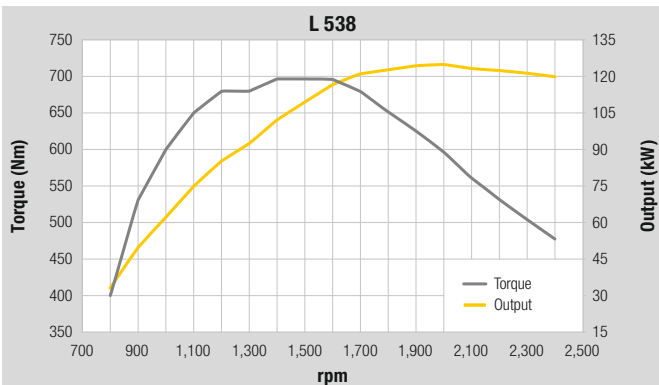



## Axles

	L 526	L 538	L 546
<b>Four-wheel drive</b>			
<b>Front axle</b>	Fixed		
<b>Rear axle</b>	Centre pivot, with 10° oscillating angle to each side		
Height of obstacles which can be driven over	mm 470	470	470
	with all four wheels remaining in contact with the ground		
<b>Differentials</b>	Automatic limited-slip differentials with 45 % locking action in both axles		
<b>Reduction gear</b>	Planetary final drive in wheel hubs		
<b>Track width</b>	1,960 mm with all types of tyres (L 526) 1,900 mm with all types of tyres (L 538, L 546)		

## Steering

<b>Design</b>	"Load-sensing" swash plate type variable flow pump with pressure cut-off and flow control. Central pivot with two double-acting steering cylinders
<b>Angle of articulation</b>	40° to each side
<b>Emergency steering</b>	Electro-hydraulic emergency steering system

## Attachment Hydraulics

	L 526	L 538	L 546
<b>Design</b>	"Load-sensing" variable axial piston pump with output and flow control, and pressure cut-off in the control block		
<b>Cooling</b>	Hydraulic oil cooling using thermostatically controlled fan and oil cooler		
<b>Filtration</b>	Return line filter in the hydraulic reservoir		
<b>Control</b>	Liebherr control lever, electro-hydraulically operated		
<b>Lifting function</b>	Lifting, neutral, lowering Float position controlled by Liebherr control lever with detent		
<b>Tilt function</b>	Tilt back, neutral, dump Automatic bucket return to dig		
<b>Max. flow</b>	l/min. 136	170	170
<b>Max. pressure</b>			
Z-bar linkage	bar 330	350	350
Parallel linkage	bar 330	350	350

## Attachment

	L 526	L 538	L 546			
<b>Geometry variants</b>	Optional					
	Powerful Z-bar linkage with tilt cylinder, hydraulic quick hitch optional					
	Parallel linkage with two tilt cylinders, hydraulic quick hitch as standard					
<b>Bearings</b>	Sealed					
<b>Cycle time at nominal load</b>	ZK	PK	ZK	PK	ZK	PK
Lifting	s 5.3	5.3	5.7	5.7	5.7	5.7
Dumping	s 2.1	4.0	2.9	4.3	2.9	4.3
Lowering (empty)	s 3.6	3.6	4.7	4.7	4.7	4.7

## Operator's Cab

<b>Design</b>	Elastic mounted, noise-proof cab ROPS roll over protection per EN ISO 3471 / EN 474-1 FOPS falling objects protection per EN ISO 3449 / EN 474-1, Cat. II Comfort safety door with 180° opening angle with rigid window, right side sliding side window, front windscreen made of laminated safety glass, green tinted as standard, side panels with single-pane safety glass ESG, green tinted, heated rear window ESG. Continuously adjustable steering column
<b>Liebherr operator's seat</b>	6 way adjustable, vibration-damped operator's seat "Comfort" with seat, depth and incline adjustment as standard (air-cushioned with seat heating adjustable to operator's weight), Liebherr control lever mounted into the operator's seat as standard
<b>Cab heating and ventilation</b>	2-level air control, cooling water heating, defroster and air conditioning via manual nozzle position or electronic valve control for head and front area, as well as electronic fresh/ recirculated air control, electrically heated rear window, filter system with pre-filter, fresh air filter and recirculated air filter, easily replaced, air condition/automatic air conditioning system with new improved cooling output optional

## Sound Level

	L 526	L 538	L 546
<b>Sound pressure level to ISO 6396</b>			
L <sub>PA</sub> (inside cab)	dB(A) 69	69	69
<b>Sound power level to 2000/14/EC</b>			
L <sub>WA</sub> (surround noise)	dB(A) 101	102	104

## Capacities

	L 526	L 538	L 546
<b>Engine oil (inclusive filter change)</b>	l 22	22	18.5
<b>Transmission</b>	l 2.5	2.5	2.5
<b>Coolant</b>	l 31	31	31
<b>Front axle/wheel hubs</b>	l 16/2.5	19/3.5	19/3.5
<b>Rear axle/wheel hubs</b>	l 16/2.5	19/3.5	19/3.5
<b>Hydraulic tank</b>	l 95	95	95
<b>Hydraulic system, total</b>	l 170	180	180

# Dimensions

## Z-bar Linkage

L 526 – L 546

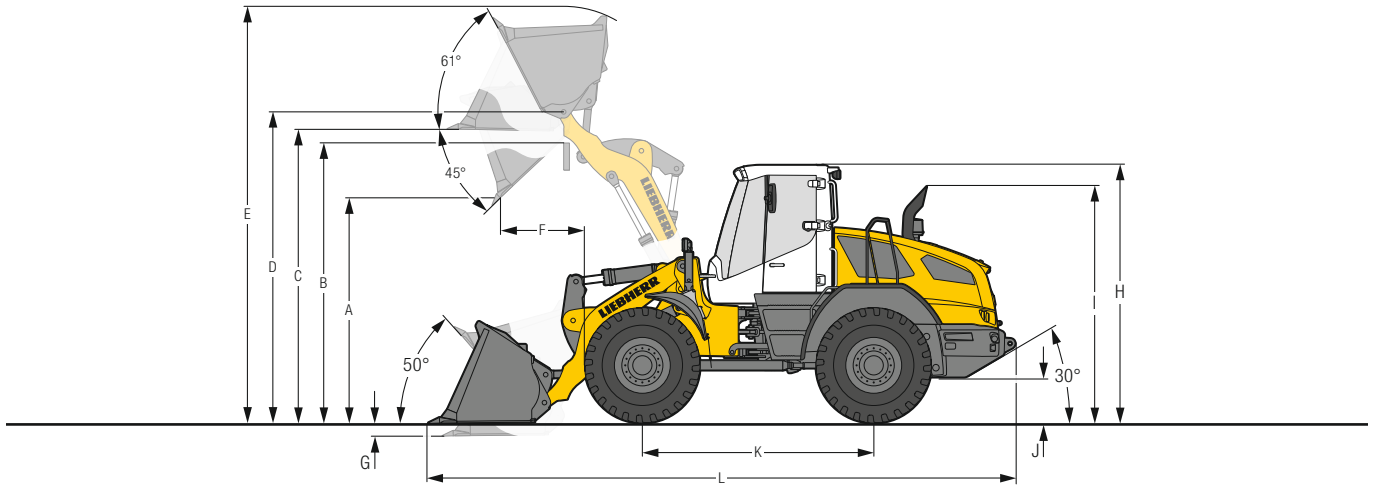

### Loading Bucket



		L 526			L 538			L 546		
		ZK	ZK-QH	ZK	ZK	ZK-QH	ZK	ZK-QH	ZK	
<b>Geometry</b>		ZK	ZK-QH	ZK	ZK	ZK-QH	ZK	ZK-QH	ZK	
<b>Cutting tools</b>		T	T	BOCE	T	T	BOCE	T	BOCE	
<b>Lift arm length</b>	mm	2,400	2,400	2,400	2,500	2,500	2,500	2,500	2,500	
<b>Bucket capacity according to ISO 7546**</b>	m <sup>3</sup>	2.1	1.8	2.3 <sup>1)</sup>	2.6	2.3	2.8 <sup>1)</sup>	2.8	2.5	
<b>Specific material density</b>	t/m <sup>3</sup>	1.8	1.8	1.7	1.8	1.8	1.7	1.8	1.8	
<b>Bucket width</b>	mm	2,500	2,500	2,500	2,500	2,500	2,500	2,500	2,500	
<b>A Dumping height at max. lift height and 45° discharge</b>	mm	2,880	2,785	2,830	2,845	2,760	2,825	2,825	2,710	
<b>B Dump-over height</b>	mm	3,400	3,390	3,390	3,480	3,480	3,480	3,480	3,480	
<b>C Max. height of bucket bottom</b>	mm	3,580	3,580	3,580	3,680	3,680	3,680	3,680	3,680	
<b>D Max. height of bucket pivot point</b>	mm	3,830	3,830	3,830	3,930	3,930	3,930	3,930	3,930	
<b>E Max. operating height</b>	mm	4,970	5,050	5,050	5,220	5,270	5,275	5,275	5,330	
<b>F Reach at max. lift height and 45° discharge</b>	mm	860	900	910	1,040	1,060	1,060	1,060	1,110	
<b>G Digging depth</b>	mm	10	5	10	40	40	40	40	40	
<b>H Height above operator's cab<sup>2)</sup></b>	mm	3,250	3,250	3,250	3,250	3,250	3,250	3,250	3,250	
<b>I Height above exhaust</b>	mm	2,950	2,950	2,950	2,950	2,950	2,950	2,950	2,950	
<b>J Ground clearance</b>	mm	510	510	510	490	490	490	490	490	
<b>K Wheelbase</b>	mm	2,925	2,925	2,925	2,975	2,975	2,975	2,975	2,975	
<b>L Overall length</b>	mm	7,280	7,380	7,255	7,530	7,610	7,470	7,560	7,680	
<b>Turning circle radius over outside bucket edge</b>	mm	5,850	5,890	5,850	6,000	6,050	6,000	6,020	6,080	
<b>Breakout force (SAE)</b>	kN	95	86	89	110	100	106	115	105	
<b>Tipping load, straight*</b>	kg	9,100	8,600	10,000	10,700	10,200	11,600	11,900	11,200	
<b>Tipping load, fully articulated*</b>	kg	8,000	7,520	8,800	9,500	9,000	10,200	10,500	9,800	
<b>Operating weight*</b>	kg	11,770	11,920	12,370	13,500	13,700	14,000	14,200	14,400	
<b>Tyre size</b>		20.5R25 L3			20.5R25 L3			20.5R25 L3		

\* The figures shown include the above tyres, all lubricants, a full fuel tank, the ROPS/FOPS cab and the operator. Different tyres and optional equipment will change the operating weight and tipping load. (Tipping load, fully articulated according to ISO 14397-1)

\*\* Actual bucket capacity may be approx. 10 % larger than the calculation according to ISO 7546 standard. The degree to which the bucket can be filled depends on the material – see page 24/25.

<sup>1)</sup> Toothed buckets, hydraulic quick hitch and additional hydraulic circuits are not approved for rehandling application.

<sup>2)</sup> The "Comfort safety door (open through 180°)" increases the value "H" to 130 mm when the door is open.

= Excavation bucket with back grading edge for direct mounting

= Excavation bucket with back grading edge for quick hitch

= Rehandling bucket for direct mounting

ZK = Z-bar linkage

ZK-QH = Z-bar linkage incl. quick hitch

T = Welded-on tooth holder with add-on teeth

BOCE = Bolt-on cutting edge

# Dimensions

## Parallel Linkage

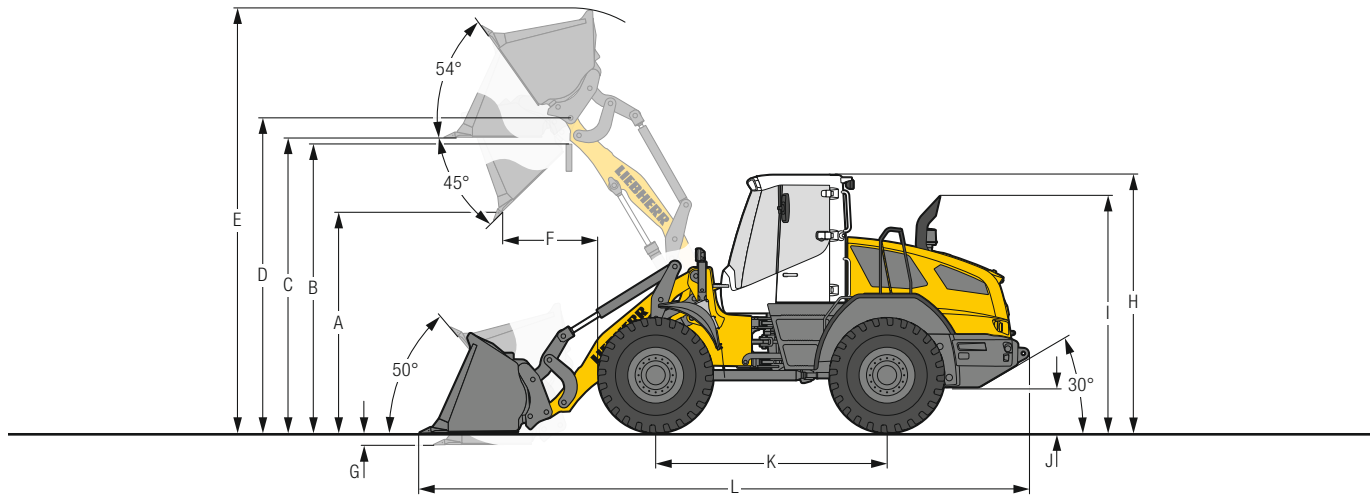

### Excavation Bucket

	L 526		L 538		L 546		
	STD	HL	STD	HL	STD	HL	
<b>Geometry</b>	PK-QH	PK-QH	PK-QH	PK-QH	PK-QH	PK-QH	
<b>Cutting tools</b>	T	T	T	T	T	T	
<b>Lift arm length</b>	mm	2,570	3,000	2,570	3,000	2,570	3,000
<b>Bucket capacity according to ISO 7546**</b>	m <sup>3</sup>	2.1	2.1	2.3	2.3	2.5	2.5
<b>Specific material density</b>	t/m <sup>3</sup>	1.8	1.5	1.8	1.5	1.8	1.5
<b>Bucket width</b>	mm	2,500	2,500	2,500	2,500	2,500	2,500
<b>A Dumping height at max. lift height and 45° discharge</b>	mm	2,850	3,410	2,790	3,350	2,740	3,305
<b>B Dump-over height</b>	mm	3,455	4,040	3,480	4,040	3,480	4,040
<b>C Max. height of bucket bottom</b>	mm	3,685	4,265	3,680	4,260	3,680	4,260
<b>D Max. height of bucket pivot point</b>	mm	3,935	4,510	3,930	4,510	3,930	4,510
<b>E Max. operating height</b>	mm	5,210	5,770	5,290	5,860	5,350	5,910
<b>F Reach at max. lift height and 45° discharge</b>	mm	1,110	1,025	1,110	1,030	1,160	1,080
<b>G Digging depth</b>	mm	45	15	55	25	55	25
<b>H Height above operator's cab<sup>1)</sup></b>	mm	3,250	3,250	3,250	3,250	3,250	3,250
<b>I Height above exhaust</b>	mm	2,950	2,950	2,950	2,950	2,950	2,950
<b>J Ground clearance</b>	mm	510	510	490	490	490	490
<b>K Wheelbase</b>	mm	2,925	2,925	2,975	2,975	2,975	2,975
<b>L Overall length</b>	mm	7,690	8,220	7,720	8,260	7,790	8,330
<b>Turning circle radius over outside bucket edge</b>	mm	5,950	6,220	6,090	6,370	6,110	6,390
<b>Breakout force (SAE)</b>	kN	100	100	108	108	112	112
<b>Tipping load, straight*</b>	kg	9,300	7,670	10,300	8,410	10,920	9,000
<b>Tipping load, fully articulated*</b>	kg	8,000	6,750	9,100	7,350	9,750	7,800
<b>Operating weight*</b>	kg	13,140	13,400	13,900	14,160	14,300	14,560
<b>Tyre size</b>		20.5R25 L3		20.5R25 L3		20.5R25 L3	

\* The figures shown include the above tyres, all lubricants, a full fuel tank, the ROPS/FOPS cab and the operator. Different tyres and optional equipment will change the operating weight and tipping load. (Tipping load, fully articulated according to ISO 14397-1)

\*\* Actual bucket capacity may be approx. 10 % larger than the calculation according to ISO 7546 standard. The degree to which the bucket can be filled depends on the material – see page 24/25.

<sup>1)</sup> The "Comfort safety door (open through 180°)" increases the value "H" to 130 mm when the door is open.

STD = Standard lift arm length

HL = High Lift

PK-QH = Parallel linkage incl. quick hitch

T = Welded-on tooth holder with add-on teeth

# Attachment

## Light Material Bucket

L 526 – L 546

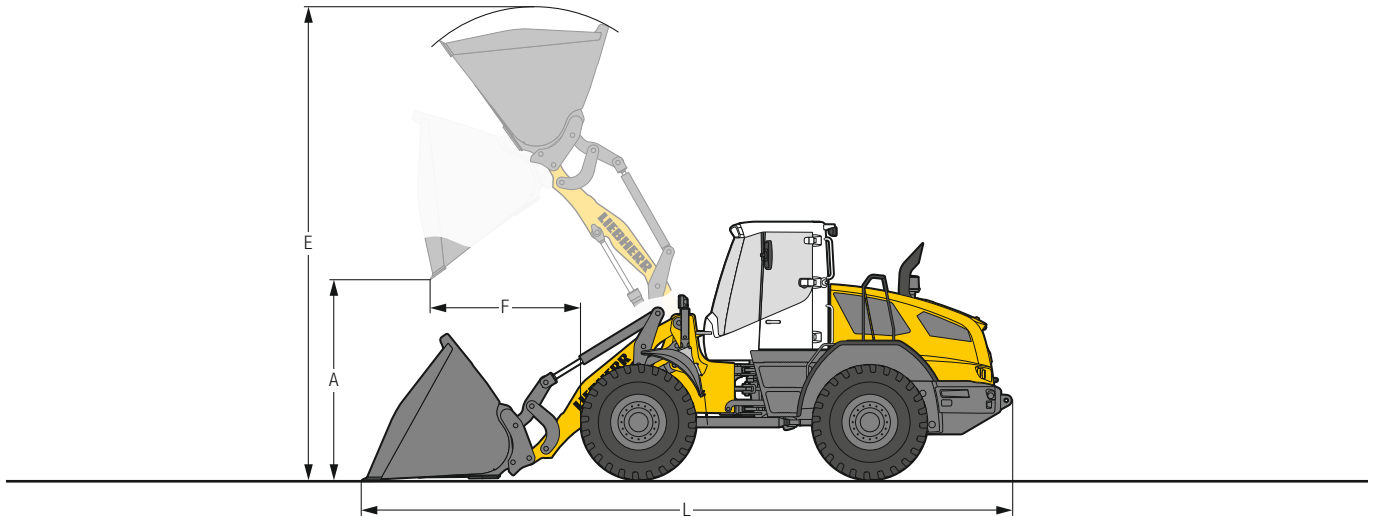

### Heavy Material Density



	L 526		L 538		L 546	
	STD	HL	STD	HL	STD	HL
Geometry	PK-QH	PK-QH	PK-QH	PK-QH	PK-QH	PK-QH
Cutting tools	BOCE	BOCE	BOCE	BOCE	BOCE	BOCE
Bucket capacity	m <sup>3</sup> 3.5	3.0	4.0	3.5	4.5	4.0
Specific material density	t/m <sup>3</sup> 1.0	0.9	1.0	0.9	1.0	0.9
Bucket width	mm 2,700	2,700	2,700	2,700	2,700	2,700
A Dumping height at max. lift height	mm 2,555	3,250	2,490	3,140	2,380	3,110
E Max. operating height	mm 5,460	5,970	5,585	6,020	5,705	6,170
F Reach at maximum lift height	mm 1,390	1,155	1,360	1,230	1,470	1,260
L Overall length	mm 7,940	8,290	7,955	8,450	8,110	8,500
Tippling load, straight*	kg 8,750	7,420	9,900	8,000	10,200	8,700
Tippling load, fully articulated*	kg 7,700	6,520	8,730	7,040	9,010	7,600
Operating weight*	kg 13,470	13,570	14,100	14,450	14,710	14,740
Tyre size	20.5R25 L3		20.5R25 L3		20.5R25 L3	

### Light Material Density



	L 526		L 538		L 546	
	STD	HL	STD	HL	STD	HL
Geometry	PK-QH	PK-QH	PK-QH	PK-QH	PK-QH	PK-QH
Cutting tools	BOCE	BOCE	BOCE	BOCE	BOCE	BOCE
Bucket capacity	m <sup>3</sup> 5.5	4.5	6.5	5.5	7.5	6.5
Specific material density	t/m <sup>3</sup> 0.5	0.5	0.5	0.5	0.5	0.5
Bucket width	mm 2,700	2,700	2,700	2,700	3,000	2,700
A Dumping height at max. lift height	mm 2,255	2,960	2,160	2,845	2,160	2,790
E Max. operating height	mm 5,845	6,300	5,995	6,410	5,995	6,580
F Reach at maximum lift height	mm 1,690	1,440	1,670	1,520	1,670	1,570
L Overall length	mm 8,350	8,710	8,420	8,860	8,420	8,970
Tippling load, straight*	kg 8,200	6,900	9,400	7,700	10,030	8,300
Tippling load, fully articulated*	kg 7,150	6,080	8,300	6,730	8,750	7,260
Operating weight*	kg 13,770	13,880	14,680	14,750	15,150	15,310
Tyre size	20.5R25 L3		20.5R25 L3		20.5R25 L3	

\* The figures shown include the above tyres, all lubricants, a full fuel tank, the ROPS/FOPS cab and the operator. Different tyres and optional equipment will change the operating weight and tipping load. (Tipping load, fully articulated according to ISO 14397-1)

STD = Standard lift arm length  
 HL = High Lift  
 PK-QH = Parallel linkage incl. quick hitch  
 BOCE = Bolt-on cutting edge

# Attachment

## High-Dump Bucket

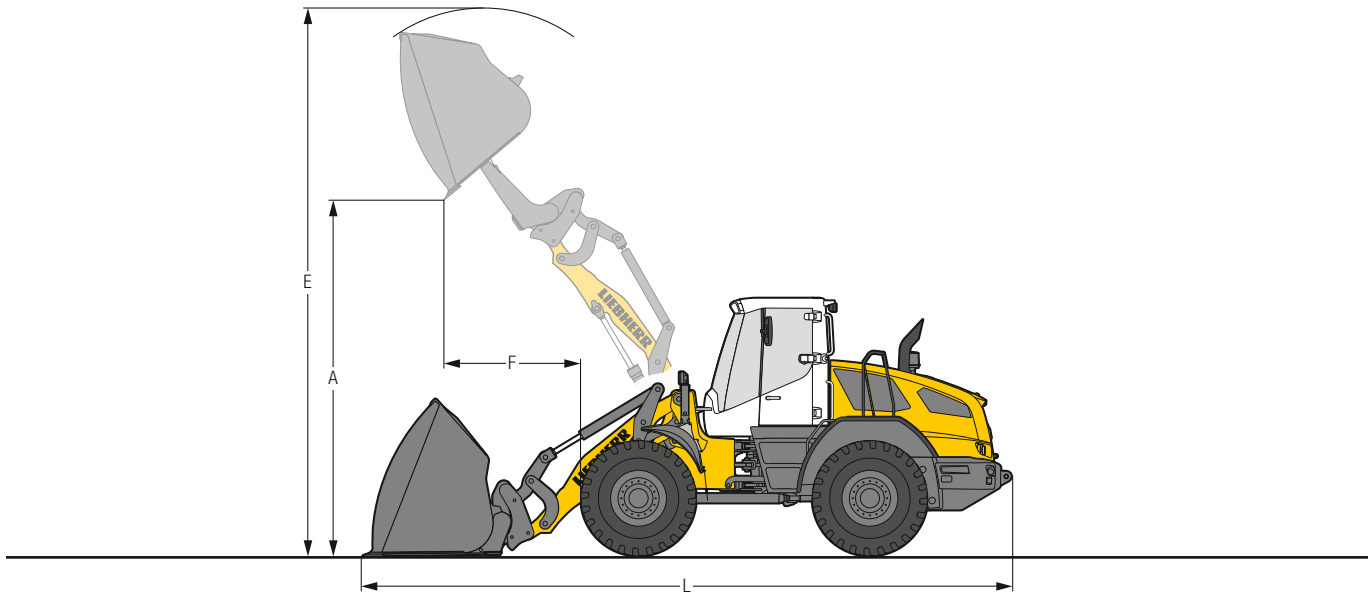

### Heavy Material Density



	L 526		L 538		L 546	
	STD	HL	STD	HL	STD	HL
Geometry	PK-QH	PK-QH	PK-QH	PK-QH	PK-QH	PK-QH
Cutting tools	BOCE	BOCE	BOCE	BOCE	BOCE	BOCE
Bucket capacity	m <sup>3</sup> 3.0	2.5	3.5	3.0	4.0	3.5
Specific material density	t/m <sup>3</sup> 1.0	0.9	1.0	0.9	1.0	0.9
Bucket width	mm 2,700	2,500	2,700	2,700	2,700	2,700
A Dumping height at max. lift height	mm 4,610	5,040	4,560	5,320	4,470	5,300
E Max. operating height	mm 6,350	6,800	6,420	6,985	6,410	7,095
F Reach at maximum lift height	mm 1,465	1,240	1,460	1,250	1,550	1,270
L Overall length	mm 8,080	8,530	8,080	8,590	8,210	8,620
Tippling load, straight*	kg 7,700	6,650	8,800	7,100	9,280	7,680
Tippling load, fully articulated*	kg 6,790	5,830	7,720	6,280	8,200	6,760
Operating weight*	kg 14,110	14,120	14,930	15,090	15,360	15,560
Tyre size	20.5R25 L3		20.5R25 L3		20.5R25 L3	

### Light Material Density



	L 526		L 538		L 546	
	STD	HL	STD	HL	STD	HL
Geometry	PK-QH	PK-QH	PK-QH	PK-QH	PK-QH	PK-QH
Cutting tools	BOCE	BOCE	BOCE	BOCE	BOCE	BOCE
Bucket capacity	m <sup>3</sup> 5.0	4.0	6.0	5.0	7.0	5.5
Specific material density	t/m <sup>3</sup> 0.5	0.5	0.5	0.5	0.5	0.5
Bucket width	mm 2,700	2,700	2,700	2,700	3,000	2,700
A Dumping height at max. lift height	mm 4,510	5,260	4,430	5,245	4,350	5,225
E Max. operating height	mm 6,615	7,140	6,880	7,325	7,005	7,465
F Reach at maximum lift height	mm 1,675	1,470	1,700	1,460	1,600	1,490
L Overall length	mm 8,260	8,710	8,305	8,760	8,380	8,800
Tippling load, straight*	kg 7,780	6,570	9,150	7,260	9,660	7,860
Tippling load, fully articulated*	kg 6,830	5,720	8,050	6,380	8,510	6,960
Operating weight*	kg 14,210	14,220	15,000	15,190	15,800	15,580
Tyre size	20.5R25 L3		20.5R25 L3		20.5R25 L3	

\* The figures shown include the above tyres, all lubricants, a full fuel tank, the ROPS/FOPS cab and the operator. Different tyres and optional equipment will change the operating weight and tipping load. (Tipping load, fully articulated according to ISO 14397-1)

- STD = Standard lift arm length
- HL = High Lift
- PK-QH = Parallel linkage incl. quick hitch
- BOCE = Bolt-on cutting edge

# Attachment

## Fork Carrier and Fork

L 526 – L 546

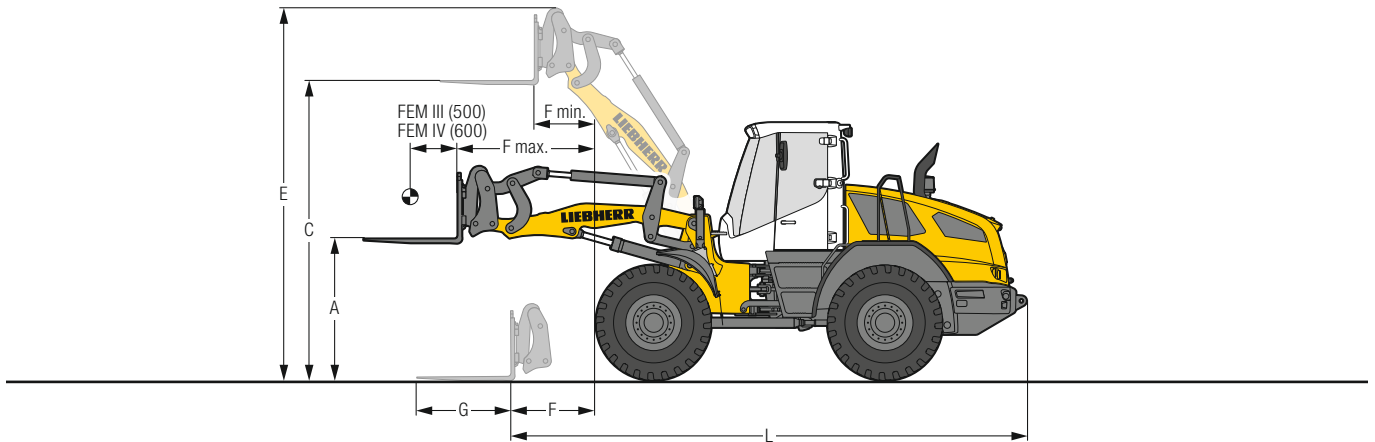

### Fork Carrier and Fork

	Fork	L 526		L 538		L 546		L 538		L 546		
		FEM III	FEM III	FEM III	FEM III	FEM III	FEM III	FEM IV	FEM IV	FEM IV	FEM IV	
	<b>Geometry</b>	ZK-QH	PK-QH	ZK-QH	PK-QH	ZK-QH	PK-QH	ZK-QH	PK-QH	ZK-QH	PK-QH	
	<b>Lift arm length</b>	mm	2,400	2,570	2,500	2,570	2,500	2,570	2,500	2,570	2,570	
<b>A</b>	<b>Lifting height at max. reach</b>	mm	1,750	1,740	1,780	1,740	1,780	1,740	1,740	1,740	1,700	
<b>C</b>	<b>Max. lifting height</b>	mm	3,640	3,745	3,740	3,740	3,740	3,740	3,700	3,705	3,705	
<b>E</b>	<b>Max. operating height</b>	mm	4,570	4,670	4,664	4,664	4,664	4,664	4,695	4,700	4,695	
<b>F</b>	<b>Reach at loading position</b>	mm	900	1,170	965	1,060	965	1,060	995	1,080	995	
<b>F max.</b>	<b>Max. reach</b>	mm	1,580	1,730	1,660	1,700	1,660	1,700	1,640	1,680	1,640	
<b>F min.</b>	<b>Reach at max. lifting height</b>	mm	660	770	710	735	710	735	690	715	690	
<b>G</b>	<b>Fork length</b>	mm	1,200	1,200	1,200	1,200	1,200	1,200	1,200	1,200	1,200	
<b>L</b>	<b>Length – basic machine</b>	mm	6,435	6,650	6,510	6,590	6,510	6,590	6,530	6,620	6,530	
	<b>Tipping load, straight*</b>	kg	6,500	7,400	7,700	8,150	8,580	8,750	7,620	8,080	8,500	
	<b>Tipping load, fully articulated*</b>	kg	5,700	6,450	6,800	7,200	7,560	7,710	6,700	7,120	7,500	
	<b>Recommended payload for uneven ground = 60% of tipping load, articulated<sup>1)</sup></b>	kg	3,290	3,700	4,050	4,320	4,520	4,620	4,000	4,270	4,480	
	<b>Recommended payload for smooth surfaces = 80% of tipping load, articulated<sup>1)</sup></b>	kg	4,200 <sup>2)</sup>	4,900	5,000 <sup>3)</sup>	5,000 <sup>3)</sup>	5,000 <sup>3)</sup>	5,000 <sup>3)</sup>	5,200 <sup>2)</sup>	5,700	5,200 <sup>2)</sup>	
	<b>Operating weight*</b>	kg	11,580	12,720	13,200	13,430	13,820	13,810	13,450	13,670	14,060	
	<b>Tyre size</b>		20.5R25 L3		20.5R25 L3		20.5R25 L3		20.5R25 L3		20.5R25 L3	

\* The figures shown include the above tyres, all lubricants, a full fuel tank, the ROPS/FOPS cab and the operator. Different tyres and optional equipment will change the operating weight and tipping load. (Tipping load, fully articulated according to ISO 14397-1)

<sup>1)</sup> According to EN 474-3

<sup>2)</sup> Payload is limited by tilt cylinder of Z-bar linkage

<sup>3)</sup> Payload is limited by FEM III fork carrier and forks to 5,000 kg

ZK-QH = Z-bar linkage incl. quick hitch

PK-QH = Parallel linkage incl. quick hitch

# Attachment

## Log Grapple

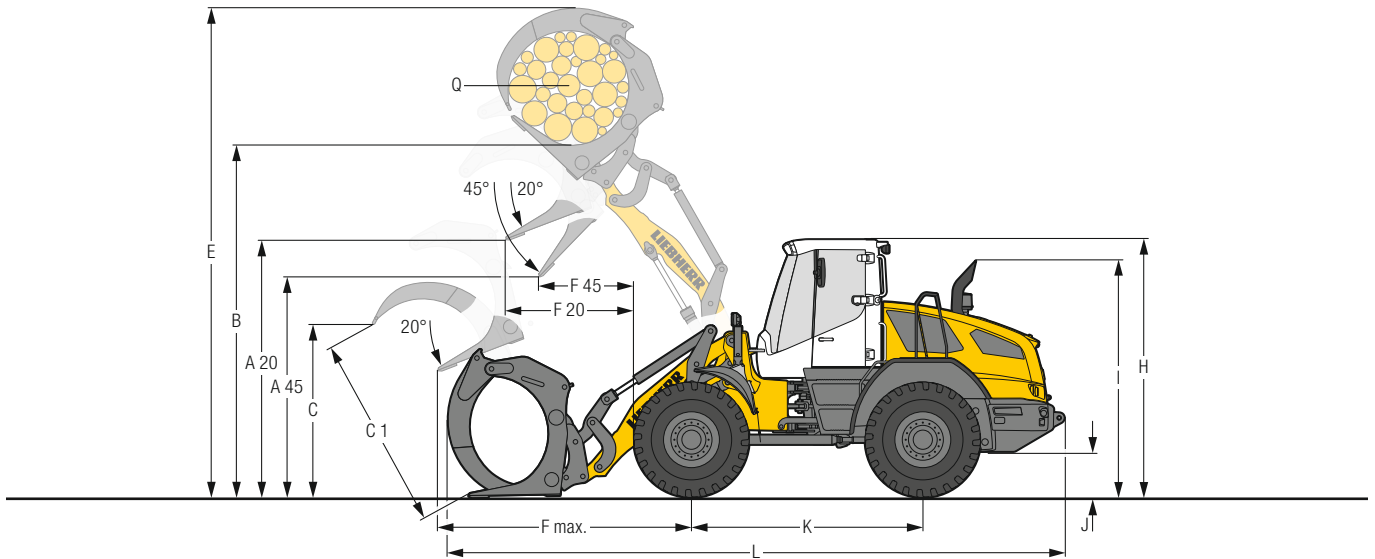

### Log Grapple

			L 526	L 538	L 546
	<b>Geometry</b>		PK-QH	PK-QH	PK-QH
A20	Discharge height at 20°	mm	3,285	3,205	3,205
A45	Discharge height at 45°	mm	2,855	2,720	2,720
B	Manipulation height	mm	4,355	4,370	4,370
C	Max. grapple opening in loading position	mm	1,910	2,325	2,325
C1	Max. grapple opening	mm	2,100	2,580	2,580
E	Max. height	mm	5,865	6,150	6,150
F20	Reach at max. lifting height at 20° discharge	mm	1,510	1,600	1,600
F45	Reach at max. lifting height at 45° discharge	mm	1,130	1,180	1,180
F max.	Max. reach	mm	2,470	2,550	2,550
H	Height above operator's cab <sup>1)</sup>	mm	3,250	3,250	3,250
I	Height above exhaust	mm	2,950	2,950	2,950
J	Ground clearance	mm	510	490	490
K	Wheelbase	mm	2,925	2,975	2,975
L	Overall length	mm	7,800	8,150	8,150
	Width over tyres	mm	2,450	2,480	2,480
Q	Grapple diameter	m <sup>2</sup>	1.3	1.8	1.8
	Grapple width	mm	1,600	1,600	1,600
	Payload*	kg	4,000	4,450	4,800
	Operating weight*	kg	13,260	14,380	14,750
	Tyre size		20.5R25 L3	20.5R25 L3	20.5R25 L3

\* The figures shown include the above tyres, all lubricants, a full fuel tank, the ROPS/FOPS cab and the operator. Different tyres and optional equipment will change the operating weight and payload.

<sup>1)</sup> The "Comfort safety door (open through 180°)" increases the value "H" to 130 mm when the door is open.

PK-QH = Parallel linkage incl. quick hitch

# Bucket Selection

L 526				Material density (t/m³)										
Lift arm	Bucket			0.4	0.6	0.8	1.0	1.2	1.4	1.6	1.8	2.0		
ZK	GPB <sub>1</sub>	2.1 m³								2.3			2.1	
	GPB <sub>2</sub>	2.3 m³*								2.5			2.3	
ZK-QH	GPB <sub>1</sub>	1.8 m³								2.0			1.8	
	GPB <sub>1</sub>	2.1 m³								2.3			2.1	
PK-QH	LMB	3.5 m³				3.9							3.5	
		5.5 m³	5.5											
	HDB	3.0 m³				3.3							3.0	
		5.0 m³	5.0											
PK-QH-HL	GPB <sub>1</sub>	2.1 m³								2.3			2.1	
		3.0 m³				3.3							3.0	
	LMB	4.5 m³	4.5											
		2.5 m³				2.8							2.5	
	HDB	4.0 m³	4.0											

\* Toothed buckets, hydraulic quick hitch and additional hydraulic circuits are not approved for rehandling application.

L 538				Material density (t/m³)										
Lift arm	Bucket			0.4	0.6	0.8	1.0	1.2	1.4	1.6	1.8	2.0		
ZK	GPB <sub>1</sub>	2.6 m³										2.9		2.6
	GPB <sub>2</sub>	2.8 m³*										3.1		2.8
ZK-QH	GPB <sub>1</sub>	2.3 m³										2.5		2.3
	GPB <sub>1</sub>	2.3 m³										2.5		2.3
PK-QH	LMB	4.0 m³								4.4			4.0	
		6.5 m³	6.5											
	HDB	3.5 m³									3.9		3.5	
		6.0 m³	6.0											
PK-QH-HL	GPB <sub>1</sub>	2.3 m³										2.5		2.3
		3.5 m³										3.9		3.5
	LMB	5.5 m³	5.5											
		3.0 m³										3.3		3.0
	HDB	5.0 m³	5.0											

\* Toothed buckets, hydraulic quick hitch and additional hydraulic circuits are not approved for rehandling application.

L 546				Material density (t/m³)										
Lift arm	Bucket			0.4	0.6	0.8	1.0	1.2	1.4	1.6	1.8	2.0		
ZK	GPB <sub>1</sub>	2.8 m³										3.1		2.8
	GPB <sub>2</sub>	3.1 m³*										3.4		3.1
ZK-QH	GPB <sub>1</sub>	2.5 m³										2.8		2.5
	GPB <sub>1</sub>	2.5 m³										2.8		2.5
PK-QH	LMB	4.5 m³										5.0		4.5
		7.5 m³	7.5											
	HDB	4.0 m³										4.4		4.0
		7.0 m³	7.0											
PK-QH-HL	GPB <sub>1</sub>	2.5 m³										2.8		2.5
		4.0 m³											4.4	
	LMB	6.5 m³	6.5											
		3.5 m³											3.9	
	HDB	5.5 m³	5.5											

\* Toothed buckets, hydraulic quick hitch and additional hydraulic circuits are not approved for rehandling application.



## Bucket Filling Factor

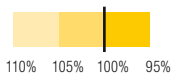

## Lift Arm

<b>ZK</b>	Z-bar linkage, standard lift arm length
<b>ZK-QH</b>	Z-bar linkage with quick hitch, standard lift arm length
<b>PK-QH</b>	Parallel linkage with quick hitch, standard lift arm length
<b>PK-QH-HL</b>	Parallel linkage with quick hitch, High Lift

## Bucket

<b>GPB<sub>1</sub></b>	General purpose bucket (Excavation bucket)
<b>GPB<sub>2</sub></b>	General purpose bucket (Rehandling bucket)
<b>LMB</b>	Light material bucket
<b>HDB</b>	High-dump bucket

## Bulk Material Densities and Bucket Filling Factors

		t/m <sup>3</sup>	%			t/m <sup>3</sup>	%			t/m <sup>3</sup>	%
<b>Gravel</b>	moist	1.9	105	<b>Earth</b>	dry	1.3	115	<b>Glass waste</b>	broken	1.4	100
	dry	1.6	105		wet excavated	1.6	110		solid	1.0	100
	crushed stone	1.5	100	<b>Topsoil</b>		1.1	110	<b>Compost</b>	dry	0.8	105
<b>Sand</b>	dry	1.5	105	<b>Basalt</b>		1.95	100	wet	1.0	110	
	wet	1.9	110	<b>Granite</b>		1.8	95	<b>Wood chips/Saw dust</b>		0.5	110
<b>Gravel and Sand</b>	dry	1.7	105	<b>Sandstone</b>		1.6	100	<b>Paper</b>	shredded/loose	0.6	110
	wet	2.0	100	<b>Slate</b>		1.75	100	recovered paper/cardboard	1.0	110	
<b>Sand/Clay</b>		1.6	110	<b>Bauxite</b>		1.4	100	<b>Coal</b>	heavy material density	1.2	110
<b>Clay</b>	natural	1.6	110	<b>Limestone</b>		1.6	100	light material density	0.9	110	
	dry	1.4	110	<b>Gypsum</b>	broken	1.8	100	<b>Waste</b>	domestic waste	0.5	100
<b>Clay/Gravel</b>	dry	1.4	110	<b>Coke</b>		0.5	110	bulky waste	1.0	100	
	wet	1.6	100	<b>Slag</b>	broken	1.8	100				

## Tipping Load



### What is tipping load?

Load at centre of gravity of working equipment, so that the wheel loader just begins to tip over the front axle. This is the most unfavourable static-load position for the wheel loader. Lifting arms horizontal, wheel loader fully articulated at centre pivot.

### Pay load.

The pay load must not exceed 50% of the tipping load when articulated. This is equivalent to a static stability-margin factor of 2.0.

### Bucket capacity.

The bucket volume is determined from the pay load.

$$\text{Pay load} = \frac{\text{Tipping load, articulated}}{2}$$

$$\text{Bucket capacity} = \frac{\text{Pay load (t)}}{\text{Specific bulk weight of material (t/m}^3\text{)}}$$

# Tyres



## Tyre Types

	Size and tread code		Change of operating weight kg	Width over tyres mm	Change in vertical dimensions* mm	Use
<b>L 526</b>						
Bridgestone	17.5R25	VJT L3	- 394	2,440	- 44	Bulk material (firm ground conditions)
Bridgestone	17.5R25	VSDL L5	119	2,450	- 5	Stone, Scrap, Recycling (firm ground conditions)
Bridgestone	20.5R25	VJT L3	17	2,480	8	Bulk material (firm ground conditions)
Bridgestone	20.5R25	VSDL L5	680	2,480	60	Stone, Scrap, Recycling (firm ground conditions)
Bridgestone	20.5R25	VSDR L5	688	2,480	60	Stone, Scrap, Recycling (firm ground conditions)
Bridgestone	550/65R25	VTS L3	- 132	2,500	- 50	Gravel (all ground conditions)
Bridgestone	650/65R25	VTS L3	605	2,650	16	Gravel (all ground conditions)
Continental	20.5R25	EM-Master L3	166	2,480	26	Bulk material (firm ground conditions)
Goodyear	17.5R25	RT-3B L3	- 320	2,460	- 41	Gravel (all ground conditions)
Goodyear	17.5R25	TL-3A+ L3	- 252	2,460	- 39	Sand, Gravel, Earthworks, Clay (all ground conditions)
Goodyear	17.5R25	RL-4K L4	36	2,460	- 20	Gravel, Industry, Stone (firm ground conditions)
Goodyear	17.5R25	RL-5K L5	160	2,460	- 20	Stone, Scrap, Recycling (firm ground conditions)
Goodyear	20.5R25	RT-3B L3	11	2,490	16	Gravel (all ground conditions)
Goodyear	20.5R25	TL-3A+ L3	156	2,500	11	Sand, Gravel, Earthworks, Clay (all ground conditions)
Goodyear	20.5R25	GP-4D L4	328	2,470	20	Gravel, Industry, Wood (firm ground conditions)
Goodyear	20.5R25	RL-5K L5	752	2,500	49	Stone, Scrap, Recycling (firm ground conditions)
Michelin	17.5R25	XTLA L2	555	2,460	- 44	Gravel, Earthworks, Clay (all ground conditions)
Michelin	17.5R25	XHA L3	- 485	2,450	- 62	Sand, Gravel (all ground conditions)
Michelin	17.5R25	XHA2 L3	- 528	2,460	- 61	Sand, Gravel (all ground conditions)
Michelin	17.5R25	XLD D2A L5	- 232	2,460	- 25	Stone, Mining spoil (firm ground conditions)
Michelin	17.5R25	X MINE PRO L5	32	2,490	- 17	Stone, Scrap, Recycling (firm ground conditions)
Michelin	20.5R25	XTLA L2	- 121	2,480	- 7	Gravel, Earthworks, Clay (all ground conditions)
Michelin	20.5R25	XHA2 L3	0	2,480	0	Sand, Gravel (all ground conditions)
Michelin	20.5R25	XLD D2A L5	431	2,480	30	Stone, Mining spoil (firm ground conditions)
Michelin	20.5R25	X MINE PRO L5	616	2,510	48	Stone, Scrap, Recycling (firm ground conditions)
Michelin	550/65R25	XLD65 L3	- 82	2,500	- 44	Gravel (all ground conditions)
Michelin	650/65R25	XLD65 L3	488	2,640	- 7	Gravel (all ground conditions)
<b>L 538/L 546</b>						
Bridgestone	20.5R25	VJT L3	17	2,480	8	Bulk material (firm ground conditions)
Bridgestone	20.5R25	VSDL L5	680	2,480	60	Stone, Scrap, Recycling (firm ground conditions)
Bridgestone	20.5R25	VSDR L5	688	2,480	60	Stone, Scrap, Recycling (firm ground conditions)
Bridgestone	550/65R25	VTS L3	- 44	2,500	- 50	Gravel (all ground conditions)
Bridgestone	650/65R25	VTS L3	595	2,650	16	Gravel (all ground conditions)
Continental	20.5R25	EM-Master L3	156	2,480	26	Bulk material (firm ground conditions)
Goodyear	20.5R25	RT-3B L3	11	2,490	16	Gravel (all ground conditions)
Goodyear	20.5R25	TL-3A+ L3	156	2,500	11	Sand, Gravel, Earthworks, Clay (all ground conditions)
Goodyear	20.5R25	GP-4D L4	328	2,470	20	Gravel, Industry, Wood (firm ground conditions)
Goodyear	20.5R25	RL-5K L5	752	2,500	49	Stone, Scrap, Recycling (firm ground conditions)
Michelin	20.5R25	XTLA L2	- 121	2,510	- 7	Gravel, Earthworks, Clay (all ground conditions)
Michelin	20.5R25	XHA2 L3	0	2,480	0	Sand, Gravel (all ground conditions)
Michelin	20.5R25	XLD D2A L5	431	2,480	30	Stone, Mining spoil (firm ground conditions)
Michelin	20.5R25	X MINE PRO L5	606	2,510	48	Stone, Scrap, Recycling (firm ground conditions)
Michelin	550/65R25	XLD65 L3	- 82	2,500	- 44	Gravel (all ground conditions)
Michelin	650/65R25	XLD65 L3	478	2,640	- 7	Gravel (all ground conditions)

\* The stated values are theoretical and may deviate in practice.

Before operating the vehicle with tyre foam filling or tyre protection chains, please discuss this with the Liebherr-Werk Bischofshofen GmbH.

# The Liebherr Wheel Loaders

## Wheel Loader



		L 506 Compact	L 507 Stereo	L 508 Compact	L 509 Stereo	L 514 Stereo
Tipping load	kg	3,450	3,750	3,850	4,430	5,750
Bucket capacity	m <sup>3</sup>	0.8	0.9	1.0	1.2	1.5
Operating weight	kg	5,180	5,550	5,600	6,390	8,860
Engine output (ISO 14396)	kW/HP	46/63	50/68	50/68	54/73	76/103

## Wheel Loader



		L 518 Stereo	L 526	L 538	L 546	L 550 XPower®
Tipping load	kg	6,550	8,000	9,500	10,500	12,200
Bucket capacity	m <sup>3</sup>	1.7	2.1	2.6	2.8	3.2
Operating weight	kg	9,190	11,770	13,500	14,200	17,700
Engine output (ISO 14396)	kW/HP	76/103	100/136	120/163	138/188	140/190

## Wheel Loader



		L 556 XPower®	L 566 XPower®	L 576 XPower®	L 580 XPower®	L 586 XPower®
Tipping load	kg	13,700	15,900	17,600	19,200	21,600
Bucket capacity	m <sup>3</sup>	3.6	4.2	4.7	5.2	6.0
Operating weight	kg	18,400	23,900	25,700	27,650	32,600
Engine output (ISO 14396)	kW/HP	165/224	200/272	215/292	230/313	260/354

12.19

## Environmental Protection Can Help You Earn Money!

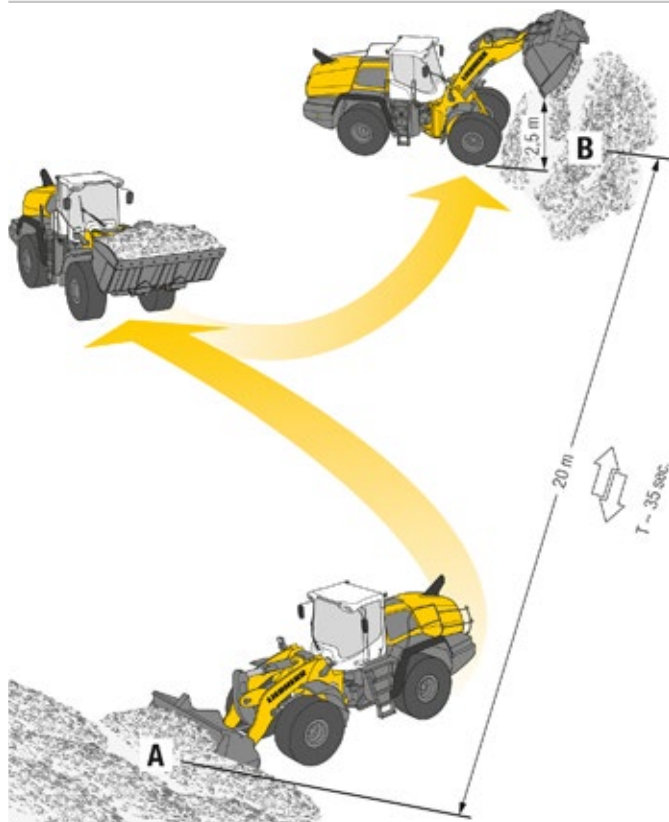

### The Liebherr Standard Consumption Test – easy to reproduce and practical.

The Liebherr Standard Consumption Test determines the number of loading cycles that can be carried out with 5 litres of diesel. The material is taken from pile A and carried over a distance of 20 metres to point B. The time needed for each working cycle should be 35 seconds. Discharge at point B should take place from a height of 2.5 m. The working cycles continue until the 5 litres of diesel in the external measuring tank have been used up. The loader's fuel consumption per operating hour is calculated as follows:

$$\frac{400}{\text{Number of loading cycles}} = \text{Consumption per hour}$$

### Values for the Liebherr wheel loaders

	Numbers of working cycles	Litres / 100 tons	Litres / hour	Ø Litres / hour*
L 526: 2,1 m <sup>3</sup>	n = 48	2.8	8.3	6.1
L 538: 2,6 m <sup>3</sup>	n = 40	2.7	10.0	6.8
L 546: 2,8 m <sup>3</sup>	n = 38	2.6	10.5	7.0
L 550: 3,2 m <sup>3</sup>	n = 32	2.7	12.5	9.0
L 556: 3,6 m <sup>3</sup>	n = 29	2.7	13.8	9.9
L 566: 4,2 m <sup>3</sup>	n = 22	3.0	18.2	12.0
L 576: 4,7 m <sup>3</sup>	n = 21	2.8	19.1	12.6
L 580: 5,2 m <sup>3</sup>	n = 20	2.7	20.0	13.7
L 586: 6,0 m <sup>3</sup>	n = 15	3.1	26.7	16.4

\* Wheel loader in practical customer applications with individual machine configurations. Average data from LiDAT from 13.03.2020.



Experience just how much fuel you can save!  
[www.encyplus.liebherr.com](http://www.encyplus.liebherr.com)

# Equipment

 <b>Basic Wheel Loader</b>	L 526	L 538	L 546
Crash protection, rear	+	+	+
Crash protection, rear with guard	+	+	+
Automatic central lubrication system	+	+	+
Battery main switch (lockable)	+	+	+
Electronic tractive force regulation for difficult ground conditions	•	•	•
Exhaust tail pipe in stainless steel	+	+	+
Travel light on front section halogen	•	•	•
Travel light on front section LED	+	+	+
Ride control	+	+	+
Parking brake	•	•	•
Fire extinguisher 6 kg	+	+	+
Fluff trap for radiator	+	+	+
Speed limitation 20 km/h as a factory preset	+	+	+
Speed limitation V <sub>max</sub> adjustable key on the control unit	•	•	•
DEF tank	•	•	•
Pre-heat system for cold starting	•	•	•
Rear license panel light	+	+	+
Combined inching-braking system	•	•	•
Mudguard in plastic design	•	•	•
Steel mudguard	+	+	+
Steel fuel tank	+	+	+
Fuel pre-filter	•	•	•
Fuel pre-filter with pre-heating	+	+	+
Large-mesh radiator	+	+	+
Cooling water pre-heating 230 V	+	+	+
Multi-disc limited slip differentials in both axles	•	•	•
Liebherr biodegradable hydraulic oil	+	+	+
Reversible fan drive	+	+	+
Automatic delayed engine stop	+	+	+
Widening for mudguard	+	+	+
Guard for headlights	+	+	+
SCR technology incl. diesel particle filter	•	•	•
Auxiliary heater (Additional heating with engine preheating)	+	+	+
Lockable doors and engine hood	•	•	•
Chassis protection rear	+	+	+
Chassis protection front	+	+	+
Air pre-cleaner TOP AIR	+	+	+
Toolbox with toolkit	+	+	+
Liebherr weighing system with "Truck Payload Assist" (cannot be calibrated)	+	+	+
Towing hitch	•	•	•

 <b>Equipment</b>	L 526	L 538	L 546
Working hydraulics lockout	•	•	•
Automatic bucket return programmable	•	•	•
Stroke limit damping	+	+	+
Fork carrier and pallet forks	+	+	+
High-dump bucket	+	+	+
Log grapple	+	+	+
Automatic lift arm position and lowering programmable	•	•	•
Lift arm parallel linkage	+	+	+
Lift arm parallel linkage High Lift	+	+	+
Lift arm Z-bar linkage	•	•	•
Hydraulic quick hitch	+	+	+
Hydraulic quick hitch LIKUFIX	+	+	+
Adjustable tipping speed	•	•	•
Tilt cylinder protection	+	+	+
Loading buckets incl. a range of cutting tools	+	+	+
Light material bucket	+	+	+
Load holding valves	+	+	+
Float position	•	•	•
Visualisation of the equipment position	•	•	•
1st and 2nd electro-hydraulic, proportional additional function, adjustable delivery flow	+	+	+
1st and 2nd additional electro-hydraulic function for continuous sweeper and snow blower operation	+	+	+

# Equipment

 Operator's Cab	L 526	L 538	L 546
Adapter plate for additional fastening on the multi-function rail	•	•	•
Adaptive working lighting	+ + +		
Access assistance to facilitate cleaning windscreen	•	•	•
Exterior mirror, electrical adjustable, with heating	+ + +		
Exterior mirror, tiltable and adjustable	•	•	•
Fold-out window left	+ + +		
Operating hour meter (integrated in display unit)	•	•	•
Operating hour meter (mechanic)	+ + +		
Electronical theft protection with code	+ + +		
Electronical theft protection with key with/without driver identification	+ + +		
Operator's cab without steering wheel/ steering column (not available as street legal) – joystick steering only	+ + +		
Operator seat "Comfort" – air sprung with seat heating	•	•	•
Operator seat "Premium" – active air-suspension with seat air-condition, seat heating and headrest	+ + +		
Particle filter F7	•	•	•
Fire extinguisher in cab 2 kg	+ + +		
Rear window heated electrically	•	•	•
Audible horn control integrated into Liebherr control lever	+ + +		
Interior mirror left	+ + +		
Integral tyre pressure monitoring system	+ + +		
Joystick steering	+ + +		
Floor mat	•	•	•
Clothes hook	•	•	•
Air conditioning system	+ + +		
Automatic air conditioning system	+ + +		
Comfort safety door (open through 180°)	•	•	•
Cool box	+ + +		
Steering column height-adjustable	+ + +		
Steering column folding	•	•	•
Steering stabilisation	•	•	•
LiDAT total use 1 year (for free)	•	•	•
Liebherr control lever with mini-joystick for 1st and 2nd electro-hydraulic, proportional additional function moving with operator's seat	+ + +		
Liebherr control lever moving with operator's seat (incl. travel direction)	•	•	•
Liebherr multi-lever control system moving with operator's seat (incl. travel direction)	+ + +		
Premiumdisplay (Touchscreen), with height adjustment and tilting function	•	•	•
Preparation for radio installation	+ + +		
Radio Liebherr "Comfort" (USB/AUX/BLUETOOTH/handsfree set)	+ + +		
Radio Liebherr "Standard" (USB/AUX)	+ + +		

 Operator's Cab	L 526	L 538	L 546
Amber beacon swiveling LED	+ + +		
Soundproof ROPS/FOPS cab	•	•	•
Bucket return with button integrated into Liebherr control lever	+ + +		
Wipe and wash system	•	•	•
Windscreen wiper single-sweep function with button	+ + +		
Headlights rear, single design, halogen/LED	+ + +		
Headlights rear, double design, halogen/LED	+ + +		
Headlights rear, triple design, LED	+ + +		
Headlights front, double design, halogen	•	•	•
Headlights front, double design, LED	+ + +		
Headlights activation (on the cab) for reverse travel	+ + +		
Sliding window right	•	•	•
Slipcover for operator seat	+ + +		
Windscreen guard	+ + +		
Sunblind front/rear	+ + +		
Power socket 12 V	•	•	•
Power socket USB	•	•	•
First aid kit	+ + +		
Preparation for protective ventilation and dust filtrating device	+ + +		
Wide angle mirror	+ + +		
Cigarette lighter	•	•	•
2-in-1 steering – changeable	+ + +		

 Safety	L 526	L 538	L 546
Active personnel detection at the rear	+ + +		
Roof camera for front area monitoring (with Liebherr camera via Liebherr display)	+ + +		
Country-specific versions	+ + +		
Emergency steering system	•	•	•
Reversing obstruction detector	+ + +		
Back-up alarm acoustical/visual	+ + +		
Rear space monitoring with camera (with Liebherr camera via Liebherr display)	•	•	•
Skyview 360°	+ + +		

- = Standard
- + = Option
- = not available

Further information can be found in the brochure "Assistance systems for wheel loaders" or you can find here:



# The Liebherr Group of Companies



## Wide Product Range

The Liebherr Group is one of the largest construction equipment manufacturers in the world. Liebherr's high-value products and services enjoy a high reputation in many other fields. The wide range includes domestic appliances, aerospace and transportation systems, machine tools and maritime cranes.

## Exceptional Customer Benefit

Every product line provides a complete range of models in many different versions. With both their technical excellence and acknowledged quality, Liebherr products offer a maximum of customer benefits in practical applications.

## State-of-the-art Technology

To provide consistent, top quality products, Liebherr attaches great importance to each product area, its components and core technologies. Important modules and components are developed and manufactured in-house, for instance the entire drive and control technology for construction equipment.

## Worldwide and Independent

Hans Liebherr founded the Liebherr family company in 1949. Since then, the family business has steadily grown to a group of more than 130 companies with more than 48,000 employees located on all continents. The corporate headquarters of the Group is Liebherr-International AG in Bulle, Switzerland. The Liebherr family is the sole owner of the company.

[www.liebherr.com](http://www.liebherr.com)

## Liebherr-Werk Bischofshofen GmbH

Postfach 49, A-5500 Bischofshofen

☎ +43 50809 1-0, Fax +43 50809 11385

[www.liebherr.com](http://www.liebherr.com), E-Mail: [info.lbh@liebherr.com](mailto:info.lbh@liebherr.com)

[www.facebook.com/LiebherrConstruction](https://www.facebook.com/LiebherrConstruction)